



# Quincy QSI



QUINCY QSI 90-225  
ROTARY SCREW  
AIR COMPRESSOR  
20-50 HP

## QUINCY QSI 90-225



Quincy now provides the efficiency and reliability that the Quincy QSI has become known for in a package that fits your business needs. From 90 CFM to 225 CFM, the Quincy QSI delivers many of the same features and benefits of our larger air compressors in a package to fit your application. The Quincy QSI direct-drive rotary screw compressor is more than just your typical “box of air”- it’s the leader in per-

formance. Combine reliability with the most efficient airend available and you start to see a QSI. Backed by Quincy Compressor’s Industry Leading 10- Year Royal Blue Warranty, the QSI features an exclusive triplex bearing arrangement, triple lip shaft seal and an airend designed to last over 100,000 hours. The QSI delivers maximum air flow with minimum horsepower.

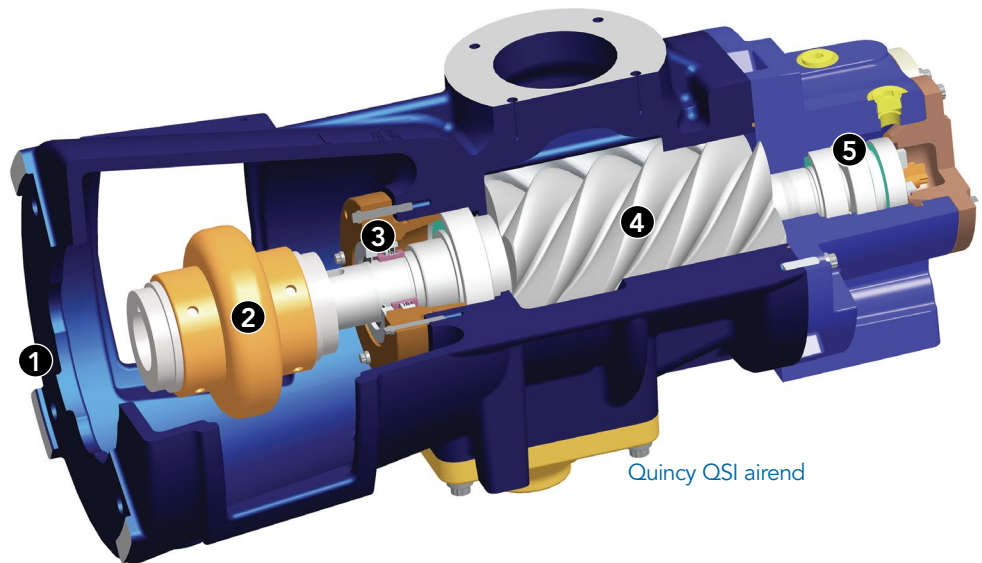

- 1** Using a standard C-Face mounted motor ensures that the motor and compressor will be properly aligned when the compressor leaves our factory... and stay that way.
- 2** The integrated mounting flange allows access for coupling maintenance. The flexible dropout coupling can be replaced without removing the motor!
- 3** A cartridge-style, triple-lip seal arrangement ensures the oil stays in and contaminants stay out.
- 4** Designed to be direct driven with no gearing or belts involved, the Quincy QSI compressor rotors provide an optimal balance between efficiency and reliability.
- 5** The Quincy QSI utilizes cylindrical roller bearings to handle radial loads and a separate tapered roller bearing for thrust loads. This arrangement ensures long, reliable compressor life under the most demanding conditions.

## ENGINEERED RELIABILITY

Quincy Compressor engineers reliability into every air compressor we manufacture. Do you want to buy an air compressor that you will have to replace in 40,000 to 50,000 hours? If you want a compressor with an engineered running life of 100,000 plus hours, the Quincy QSI fulfills your needs, allowing your compressed air system to be one less thing that you have to worry about.

## MAINTAIN CONTROL

Maintaining control and overseeing operating the parameters of your operation is vital to maximizing your profitability. Because your air compressor is more than just another piece of capital equipment, it is necessary to maintain optimal control over your compressed air system to maximize your energy efficiency and maintain peak air system performance, whatever the environment you may have.

## MICROPROCESSOR CONTROL

The Quincy QSI provides you with one of the most intuitive controllers on the market, combine that with touchscreen technology and you can keep in touch with your air compressor and maintain peak efficiency.

- Full-color 6" touchscreen controller with interactive trending analysis
- Intuitive controls mean that you don't have to learn menus or complex codes



## GAUGE CONTROL

When the most demanding applications arise, the Quincy gauge controls option provides you with simplicity and reliability.

- Silicon-dampened movements provide you with accuracy of liquid filled gauges without potential for troublesome leaks
- Three gauges, pressure, capacity and temperature provide information at a glimpse of an eye

# QUINCY QSI 90-225



## QSI 90-225 TECHNICAL DATA

Model	100 PSI	Flow 125 PSI	150 PSI	dBA	Length inches	Width inches	Height inches	Weight lbs**
QSI 90	90	88	84	68	61.1	33	49.3	1250
w/ tank					69	33	73.8	1500
QSI 120	117	114	111	68	61.1	33	49.3	1300
w/ tank					69	33	73.8	1550
QSI 140	136	135	130	68	61.1	33	49.3	1350
w/ tank					69	33	73.8	1600
QSI 190	184	184	183	69	70.4	38	68.63	2094
QSI 225	225	220	224	69	70.4	38	68.63	2094

\*Tank-mount option available on 20-30 HP models only

## THE QUINCY COMPLETE INTEGRATED AIR PACKAGE

Breathing dirty air is not an option for you and your employees, why should it be for your tools and production equipment?

Quality air helps you provide quality products to your customers. Optimize your compressed air installation with the Quincy Complete Air Package. Quincy Compressor provides the optional complete air package to give you a complete compressor room in one compact footprint.

The Quincy Complete Integrated Air Package provides you with an air compressor, a 1 micron coalescing in line air filter, a refrigerated air dryer designed to produce a 38°F dew point, and a .01 micron polishing filter. This provides you with the compressed air that meets ISO 8573.1.1.4.1 standards for air quality.

All this means that your tools and equipment are provided with clean, quality air. This extends their operating life and reduces your maintenance and replacement costs while optimizing the profitability of your business and maintain the quality of the product that you produce.

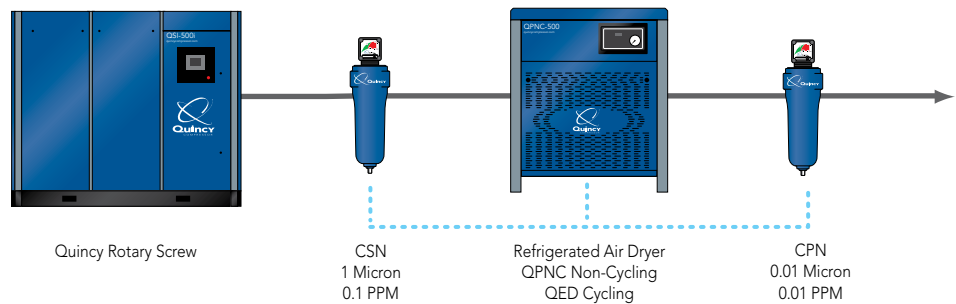

## SERVICEABILITY

---

When profitability and productivity is the bottom line for your business, it is important to minimize maintenance costs, maintenance time and unscheduled downtime. The Quincy QSI compressor has been engineered with optimal serviceability in mind.

Package pre-filtration through high performance filter media maintains clean and efficient operation of your compressed air package and proper operation of the compressor cooling system.

All major maintenance components are located behind easy to remove panels to facilitate a quick and easy preventative maintenance schedule, maximizing your uptime.

High efficiency low sound centrifugal cooling fan module provides premium efficiency and quiet operation with an easily serviceable module.



## QUINCY'S INDUSTRY LEADING 10-YEAR WARRANTY

---

Air compressor packages are often as good as the warranty and support that stands behind them. The Quincy QSI does not require you to commit to many of the long term expensive extended warranty contracts or service contracts like the competition, many at extremely high costs to you.

All Quincy QSI machines arrive at your facility backed by the industry's premier 10-Year Royal Blue Warranty. Not only is this a warranty to help protect your equipment, but it is Quincy's promise to provide premium, quality, reliable equipment to our customers on a daily basis.

### **WORLD'S BEST WARRANTY:**

10-YEAR AIREND WARRANTY, FIVE YEAR WARRANTY ON MAJOR COMPONENTS.



## VALUE

---

There is more to purchasing an air compressor solution than price. What is the real value that the Quincy QSI provides you?

Quincy provides you with...

- One source for all compressed air system needs
- Reputable network of Quincy Authorized distributors
- Factory trained service technicians
- Extensive parts inventory
- Hundreds of compressed air experts nationwide, dedicated to provide you with the correct solution

# QUINCY QSI 90-225

## EXTEND THE LIFE OF YOUR COMPRESSOR WITH GENUINE QUINCY FLUIDS

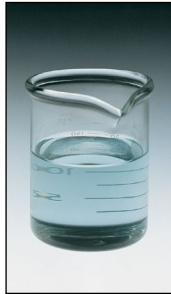

**QUIN-SYN FLUIDS** are uniquely formulated for Quincy products. Genuine Quin-Syn fluids ensure optimum performance and keeps units running smoothly for years to come.

Quincy offers an affordable lubricant system analysis program to all Genuine Quin-Syn users. Be sure to ask your authorized service center for details.

### NON-TOXIC

Unlike some lubricants, all Quin-Syn fluids are nontoxic and not considered hazardous under OSHA Hazardous Communication Standard 21 CFR1910.1200.

### EXPECTED LUBRICANT LIFE at normal operating conditions

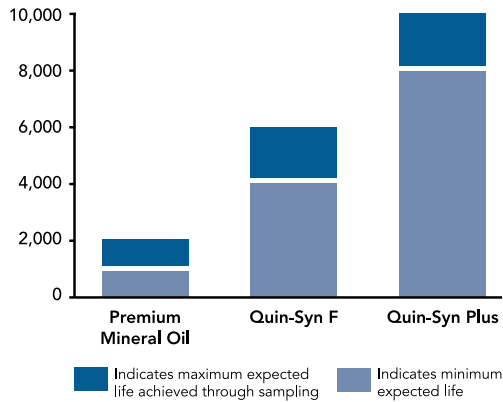

## PROUD MEMBER OF COMPRESSED AIR & GAS INSTITUTE



Member of  
Quincy Compressor proudly publishes total package ACFM which is measured and reported in accordance with industry standard CAGI/PNEUROP PN2CPTC2 guidelines. Every Quincy QSI meets or exceeds CAGI/PNEUROP PN2CPTC2 guidelines - ensuring that you get every acfm that has been promised.

## THE QUINCY PROMISE

---

Quincy Compressor and its partnering distributors promise to provide you with uncompromising reliability in all Quincy equipment. This makes your compressed air system one less thing that you need to worry about, allowing you to focus on your company's productivity and profitability.



## THE QUINCY SOLUTION

---

Operating at peak efficiency and providing quality product is a priority for many of our customers. Quincy Compressor in partnership with our global network of authorized distributors strives to be your provider for all of your compressed air system needs. From the air compressor to filtration to dryers and storage solutions, Quincy Compressor is your single source provider for all of your compressed air system needs.

### Air Compressors

Quincy Compressor is a premier provider of many different types of air compressors designed for a variety of applications using different compression technologies.

The Quincy QT is a Reciprocating Splash Lubricated compressor for tough everyday use. The Quincy QP is a reciprocating fully pressure lubricated compressor for a competitive advantage. The Quincy QR is a reciprocating compressor designed for the most demanding conditions. The Quincy QGS 5-30 HP is a heavy-duty belt driven rotary compressor at a competitive price. The Quincy QSI provides an industrial grade premium fixed speed rotary screw air compressor. The Quincy QGV provides a premium variable speed rotary screw air compressor designed to optimize your energy efficiency.

### Compressed Air Treatment

Quincy Compressor is your single-source provider of compressed air treatment products to complement your air compressor. Quincy provides refrigerated air dryers, desiccant air dryers, compressed air filtration from 5 to .01 micron, condensate drains, condensate management systems, storage solutions, and flow control valves. Quincy Compressor is truly a single-source provider for all of your compressed air needs.

### Genuine Parts

Genuine Parts from Quincy Compressor keep your equipment running like new. When servicing your Quincy compressor, insist on Genuine Quincy parts. Not only will you save time and money, but you will gain the peace-of-mind from using only the highest quality parts worthy of the Quincy name.

### System Controls

Whether you have one air compressor or many air compressors from many different manufacturers, Quincy Compressor provides you with a way to control and monitor all of the components in your compressed air system in a way that maximizes your energy efficiency and decreases your energy costs. Whether you need to control your system on site or from half way around the world, Quincy Compressor is your source for reliable, efficient controls.

# COMPRESSED AIR SYSTEMS BEST PRACTICE

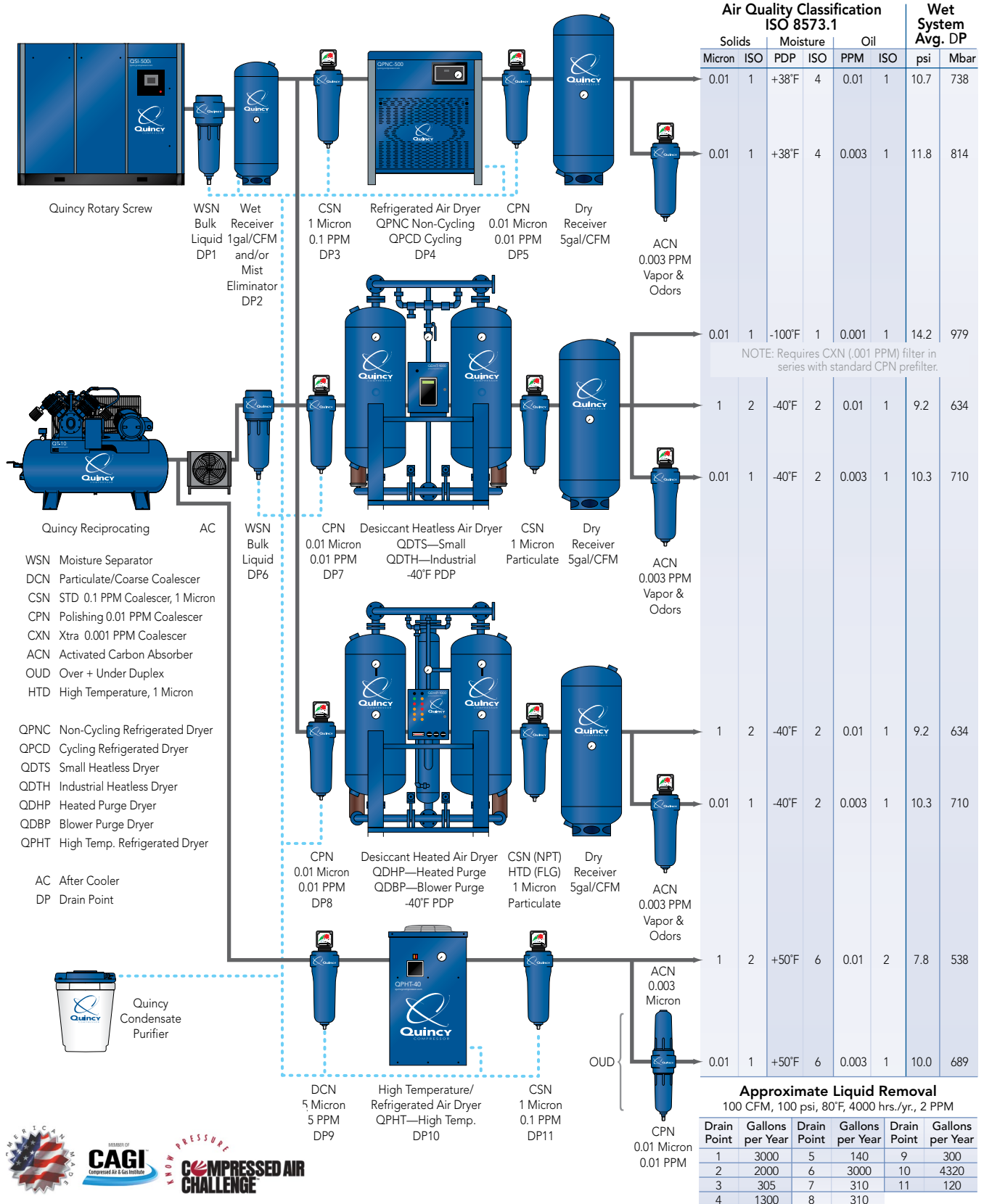

- WSN Moisture Separator
- DCN Particulate/Coarse Coalescer
- CSN STD 0.1 PPM Coalescer, 1 Micron
- CPN Polishing 0.01 PPM Coalescer
- CXN Xtra 0.001 PPM Coalescer
- ACN Activated Carbon Absorber
- ODD Over + Under Duplex
- HTD High Temperature, 1 Micron
  
- QPNC Non-Cycling Refrigerated Dryer
- QPCD Cycling Refrigerated Dryer
- QDTS Small Heatless Dryer
- QDTH Industrial Heatless Dryer
- QDHP Heated Purge Dryer
- QDBP Blower Purge Dryer
- QPHT High Temp. Refrigerated Dryer
  
- AC After Cooler
- DP Drain Point

Air Quality Classification ISO 8573.1						Wet System Avg. DP	
Solids		Moisture		Oil		psi	Mbar
Micron	ISO	PDP	ISO	PPM	ISO		
0.01	1	+38°F	4	0.01	1	10.7	738
0.01	1	+38°F	4	0.003	1	11.8	814
0.01	1	-100°F	1	0.001	1	14.2	979
1	2	-40°F	2	0.01	1	9.2	634
0.01	1	-40°F	2	0.003	1	10.3	710
1	2	-40°F	2	0.01	1	9.2	634
0.01	1	-40°F	2	0.003	1	10.3	710
1	2	+50°F	6	0.01	2	7.8	538
0.01	1	+50°F	6	0.003	1	10.0	689

NOTE: Requires CXN (.001 PPM) filter in series with standard CPN prefilter.

**Approximate Liquid Removal**  
100 CFM, 100 psi, 80°F, 4000 hrs./yr., 2 PPM

Drain Point	Gallons per Year	Drain Point	Gallons per Year	Drain Point	Gallons per Year
1	3000	5	140	9	300
2	2000	6	3000	10	4320
3	305	7	310	11	120
4	1300	8	310		

